

# FluoroSeal Specialty Valves



**LINED VALVES**

## LINED PLUG VALVES

### PRECISION CAST BODY, PLUG AND COVER

The 2-Way FluoroSeal® Lined Plug Valves use investment casting method for the major pressure holding components.

- All casting components traceable to mill test certificates
- Investment cast on all materials for sizes 1/2" – 10" (Class 150 lbs)
- Investment cast on all materials for sizes 1/2" – 6" (Class 300 lbs)
- Castings can meet Level 1 casting specifications

### CORROSION PROTECTION

FluoroSeal® standard base model offers Carbon Steel body, plug and cover (ASTM A216 Gr. WCB). Even though FluoroSeal Inc. offers the low porosity PFA (Perfluoroalkoxy) as standard, all cast parts have an epoxy based coating prior to lining for added protection from corrosion attack due to permeation.

### LOCKED-IN LINER

The 2-Way Class 150 lbs Lined Plug Valve features PFA lining applied by Transfer Molding and locked into castings by machined dove tail shaped grooves, and cast dove tail shaped recesses in body castings and cast holes. This helps prevent liner collapse in vacuum conditions and blow out in high pressure conditions in conjunction with high temperatures.

The Transfer Molding method insures equal distribution and consistency of liner throughout the entire surface of the lined components. FluoroSeal® Lined Plug Valves comply with the industry specifications (ASTM F1545) dictating the liners' uniform thickness across the entire valve and guarantee the absence of any weak section in the valve liner.

### CAVITY-FREE DESIGN

By design, Plug Valves are cavity-free both in open and closed positions. This prevents the accumulation of particles between the plug and body and makes the valve ideal for slurry applications.

### LARGE SEAL AREA

The interface between the tapered outer plug and the tapered inner body liner provides a 360° sealing area. This results in a tight shutoff. The seal is created due to compression between the plug and body, thus the valve is bi-directional and seals on both upstream and downstream sides simultaneously.



Lined Valve Section View



Lined Plug Cutaway

**IN-LINE ADJUSTMENT**

FluoroSeal® Lined Plug Valves feature the state-of-the-art EZ-Seal® (patent pending) adjustment mechanism, available on sizes 1/2" to 6". No special tooling is needed to adjust an EZ-Seal®, and the latter allows effective maintenance planning and extended service life through simple visual diagnostic. As the valve is being adjusted throughout its operational span, the Min / Max gauge integrated into the EZ-Seal® cover indicates its remaining service life. Regular visual readings of this gauge can assist plant managers and maintenance crews in scheduling of repairs and eventual line shut-downs before the wear on the valve reaches a critical point.

**QUADRUPLE ATMOSPHERIC SEAL**

Single point external adjusting bolt (patent pending) in the cover assures equilibrium to the compression of the stem and in-line seals by imparting a balanced force through a metal thrust cam inserted in the cover above the formed metal diaphragm. This system provides a definitive advantage over other adjustment options available on the market by eliminating all side loading and related wear-and-tear on the liner.

The primary seal of the plug valve is between the plug and body liner. The secondary sealing level is an integrated PTFE diaphragm with a 45° delta ring which is pressure assisted, and completely protected by a metal diaphragm. The PTFE diaphragm has a double role of plug and stem seal. The specially formed metal diaphragm assists in encapsulation, acts as an antistatic device, and is a metal seal to atmosphere, in case of PTFE failure. The combined mechanism provides an excellent, quadruple seal to atmosphere and a double (downstream & upstream) bi-directional in-line seal adjustment.

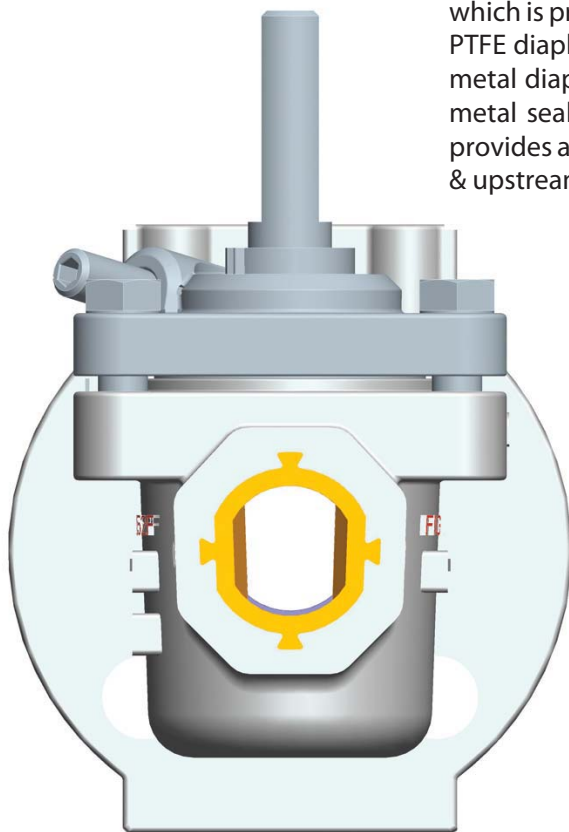

Dove Tail Liner Section

PLUG-ANSI-R001-2007

# LINED PLUG VALVES

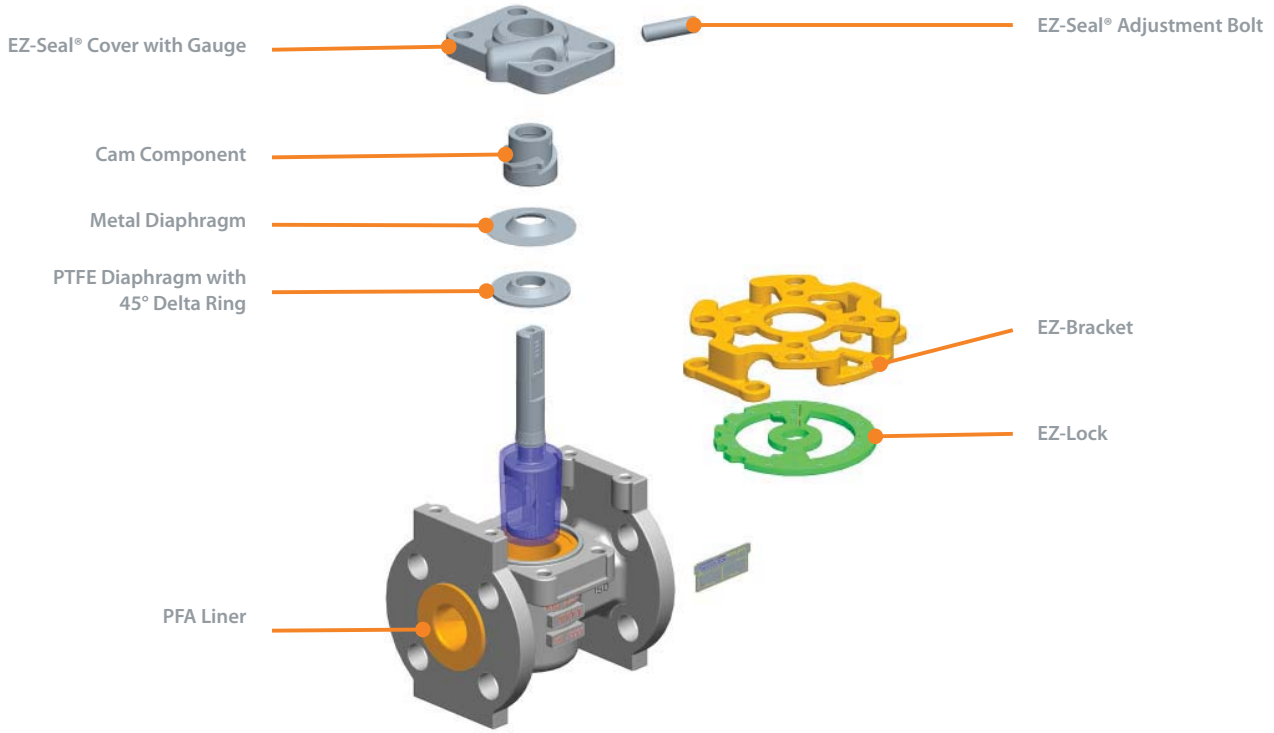

Lined Valve Exploded View

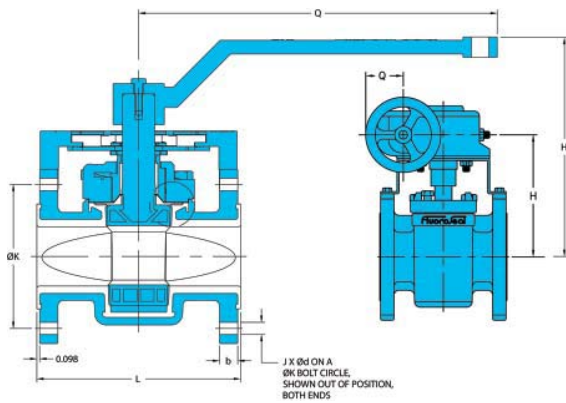

**LINED CLASS 150 LBS**  
 Flanged Ends  
 Wrench Operated  
 Actuators Optional on All Sizes

Dimensions to ANSI B16.5 & B16.10

E = Clearance for resleeving

EG = Enclosed gear operated

N = Number of holes

Two (2) top holes in flanges are tapped with UNC threads. See Hole-UNC column

SIZE	L		H		D		K		g		b		f		d		Q		E		N	Hole-UNC
	in	mm	in	mm	in	mm	in	mm	in	mm	in	mm	in	mm	in	mm	in	mm	in	mm		
1"	5.00	127.00	5.57	141.48	4.25	108.00	3.13	79.50	2.00	50.80	0.49	12.45	0.06	1.60	0.63	16.00	8.27	210.00	5.21	132.30	4	-
1 1/2"	6.50	165.10	6.80	172.72	5.00	127.00	3.88	98.60	2.88	73.20	0.59	14.99	0.06	1.60	0.63	16.00	10.33	262.40	6.41	162.80	4	-
2"	7.00	177.80	7.54	191.52	6.00	152.40	4.75	120.70	3.63	92.00	0.63	16.00	0.06	1.60	0.75	19.00	12.40	315.00	7.50	190.50	4	-
3"	8.00	203.20	8.10	205.74	7.50	190.50	6.00	152.40	5.00	127.00	0.79	20.07	0.06	1.60	0.75	19.00	12.40	315.00	8.60	218.40	4	-
4"	9.00	228.60	9.56	242.82	9.00	228.60	7.50	190.50	6.19	157.20	0.94	23.90	0.06	1.60	0.75	19.00	24.30	617.20	10.66	270.80	8	-
4" EG	9.00	228.60	11.80	299.72	9.00	228.60	7.50	190.50	6.19	157.20	0.94	23.90	0.06	1.60	0.75	19.00	7.25	184.00	10.66	270.80	8	-
6" EG	10.50	266.70	14.00	355.60	11.00	279.40	9.50	241.30	8.50	215.90	1.00	25.40	0.06	1.60	0.88	22.40	7.25	184.00	13.55	344.20	8	-
8" EG	11.50	292.10	13.00	330.20	13.50	342.90	11.75	298.50	10.63	269.80	1.13	28.70	0.06	1.60	0.88	22.40	9.75	248.00	-	-	8	3/4"-10
10" EG	13.00	330.20	14.94	379.48	16.00	406.40	14.25	362.00	12.75	323.90	1.19	30.20	0.06	1.60	1.00	25.40	9.75	248.00	-	-	12	7/8"-9
12" EG	14.00	355.60	15.69	398.53	19.00	482.60	17.00	431.80	15.00	381.00	1.25	31.80	0.06	1.60	1.00	25.40	13.75	349.25	-	-	12	7/8"-9