

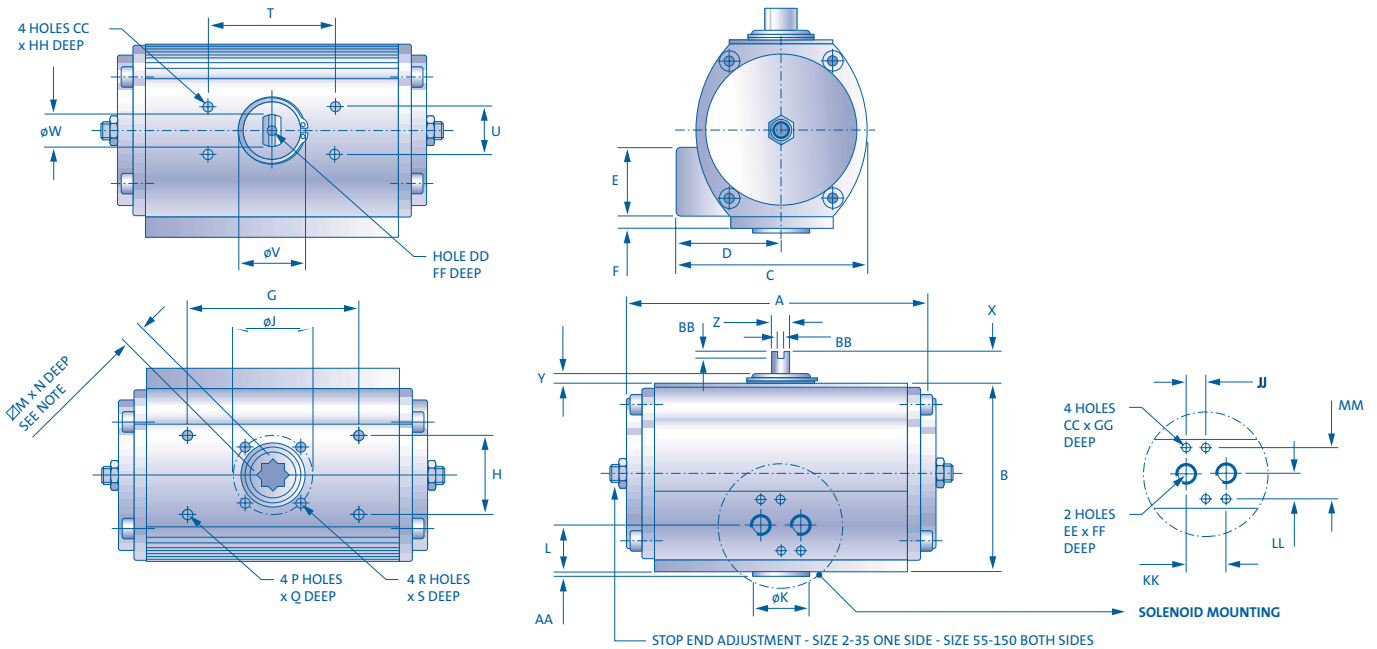

TruTorq Actuator Size 2/4/8 C-TYPE Double Acting and Spring Return



Dimensions

Metric		A	B	C	D	E	F	G	H	ØJ	ØK	L	∠M	N	P	Q	R	S	T
TT2	F03	114.5	73.0	75.5	43.5	41.0	-	73.0	32.0	36.0	25.0	20.5	9.0	10.0	M5	8.0	M5	8.0	80.0
TT4	F04	133.0	90.5	87.5	47.5	41.0	-	73.0	32.0	42.0	30.0	20.5	11.0	12.0	M5	8.0	M5	8.0	80.0
TT8	F05	162.0	109.0	105.0	57.0	42.0	7.5	73.0	32.0	50.0	35.0	28.5	14.0	16.0	M6	10.0	M6	10.0	80.0
		U	ØV	ØW	X	Y	Z	AA	BB	CC	DD	EE	FF	GG	HH	JJ	KK	LL	MM
TT2	F03	30.0	25.0	16.0	20.0	4.5	11.5	2.0	4.0	M5	M6	G1/8"	12.0	8.0	5.0	12.0	24.0	16.0	32.0
TT4	F04	30.0	31.0	20.0	20.0	5.0	11.5	3.0	4.0	M5	M6	G1/8"	12.0	8.0	5.0	12.0	24.0	16.0	32.0
TT8	F05	30.0	35.0	20.0	20.0	5.0	11.5	3.0	4.0	M5	M6	G1/8"	12.0	8.0	5.0	12.0	24.0	16.0	32.0
Imperial		A	B	C	D	E	F	G	H	ØJ	ØK	L	∠M	N	P(unc)	Q	R(unc)	S	T
TT2	F03	4.51	2.87	2.97	1.71	1.61	-	2.87	1.26	1.42	0.984	0.81	0.354	0.39	10-24	0.31	10-24	0.31	3.15
TT4	F04	5.24	3.56	3.44	1.87	1.61	-	2.87	1.26	1.65	1.181	0.81	0.433	0.47	10-24	0.31	10-24	0.31	3.15
TT8	F05	6.38	4.29	4.13	2.24	1.65	0.30	2.87	1.26	1.97	1.378	1.12	0.551	0.63	1/4-20	0.39	1/4-20	0.39	3.15
		U	ØV	ØW	X	Y	Z	AA	BB	CC(unf)	DD	EE	FF	GG	HH	JJ	KK	LL	MM
TT2	F03	1.18	0.98	0.63	0.79	0.18	0.45	0.08	0.16	10-32	M6	NPT1/8	0.5	0.31	0.2	0.47	0.94	0.63	1.26
TT4	F04	1.18	1.22	0.79	0.79	0.18	0.45	0.08	0.16	10-32	M6	NPT1/8	0.5	0.31	0.2	0.47	0.94	0.63	1.26
TT8	F05	1.18	1.38	0.79	0.79	0.2	0.45	0.12	0.16	10-32	M6	NPT1/8	0.5	0.31	0.2	0.47	0.94	0.63	1.26

Torque

MODEL	AIR SUPPLY		DA TORQUE	SR TORQUE				
	BAR	PSI		Air-start	Air-end	Spring-start	Spring-end	Spring Qty
TT2	6.0		20.5 Nm	13.25	7.31	13.20	7.26	4x4
TT4	6.0		41.6 Nm	26.92	14.88	26.68	14.64	4x4
TT8	6.0		90.0 Nm	58.32	32.40	57.60	31.68	4x4
TT2		80.0	166 in.lbs	107	59	107	59	4x3
TT4		80.0	337 in.lbs	218	121	216	119	4x3
TT8		80.0	730 in.lbs	473	263	467	257	4x3

Basic Operating Detail

- TDA = Double Acting
- Port 'A' = Air To Open (Anti-Clockwise)
- Port 'B' = Air To Close (Clockwise)
- TSR = Spring Return
- Port 'A' = Air To Open (Anti-Clockwise compressing springs)
- Port 'B' = Spring To Close (Clockwise)
- Fail Safe Open = Rotate Pistons 180° About Own Axis
- Drive Medium = Air (Dry or Lubricated); Non Corrosive Gas; Light Hydraulic Oil
- Temperature = Buna Nitrile 'O' Seals -40 to +100°C or -40 to +212°F
Viton 'O' Seals -25 to +250°C or -13 to +482°F

Actuator Size	Operating Time				Air Consumption				Overall Weight				Sol. VV Min. CV
	DA Open	DA Close	SR Open	SR Close	Open (l)	Close (l)	Open (ci)	Close (ci)	DA Kg	SR Kg	DA lbs	SR lbs	
2	<1	<1	<1	<1	0.09	0.12	5.49	7.32	1.0	1.1	2.2	2.4	0.2
4	<1	<1	<1	<1	0.18	0.24	10.98	14.65	1.8	1.9	4.0	4.2	0.2
8	<1	<1	<1	<1	0.34	0.41	20.75	25.02	3.1	3.4	6.8	7.5	0.5

■ Parts List

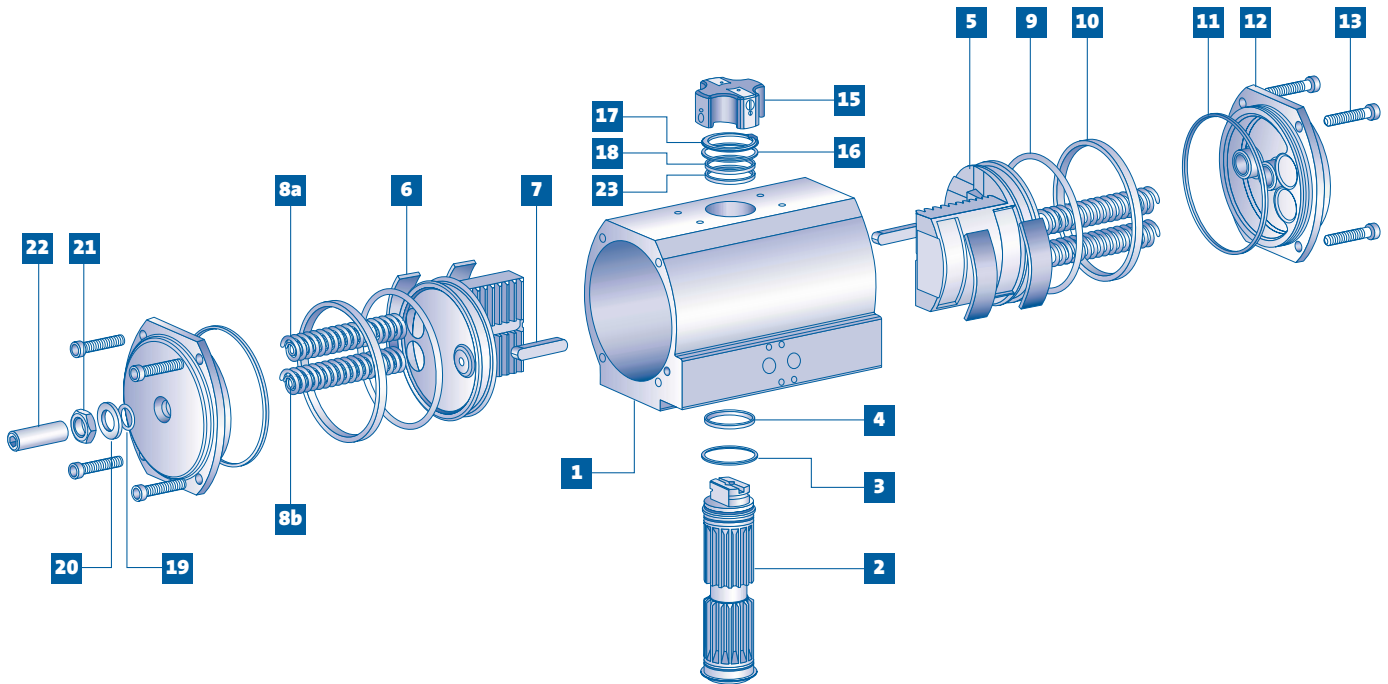

Ref No	Description	Quantity	Material Std Unit	Material CNI® Unit	Comments
1	Body	1	Alum. Anodized	Alum/CNI 530T	
2	Driveshaft	1	Steel	Stainless Steel	Option CNI 530T
3*	Washer	1	Polyethylene	Polyethylene	
4*	'O' ring	1	Buna Nitrile	Buna Nitrile	Option Viton or Silicone
5	Piston	2	Alum. Anodized	Alum/CNI 425	
6*	Wear Pads	4	POM Delrin	POM Delrin	
7*	Guide Bar	2	Steel	Stainless Steel	
8a	Spring Outer/Large	4	SiCr	SiCr	
8b	Spring Inner/Small	4	SiCr	SiCr	
9*	'O' ring	2	Buna Nitrile	Buna Nitrile	Option Viton or Silicone
10*	Back-up Bearing	2	POM Delrin	POM Delrin	
11*	'O' ring	2	Buna Nitrile	Buna Nitrile	Option Viton or Silicone
12	Endcap	2	Alum. Anodized	Alum/CNI 530T	
13	Endcap Bolt	8	Stainless Steel	Stainless Steel	
14*	Ball Seal	2	Composite	Composite	
15	Position Indicator	1	Polyethylene	Nylon	TruVision optional on STD unit
16*	Washer	1	Polyethylene	Polyethylene	
17*	Circlip	2	Steel	Stainless Steel	
18*	'O' ring	1	Polyethylene	Polyethylene	
19	Stop Adjustment 'O' ring	1	Buna Nitrile	Buna Nitrile	Option Viton or Silicone
20	Stop Adjustment Washer	1	Polyethylene	Polyethylene	
21	Stop Adjustment Nut	1	High Tensile Steel	High Tensile Steel	Dacrolit Coated
22	Stop Adjustment Screw	1	High Tensile Steel	High Tensile Steel	Dacrolit Coated
23*	Driveshaft Upper Bearing	1	POM Delrin	POM Delrina	

* Items marked with and asterisk are included in repair kit.